

### Type EV P

All normal fifth wheel couplings can be mounted on the sliding device. Standard mounting holes for the fifth wheel coupling according to DIN standard 74081 and ISO 3842 are provided.

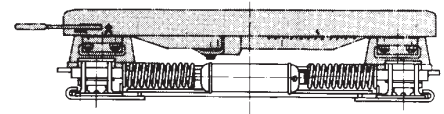
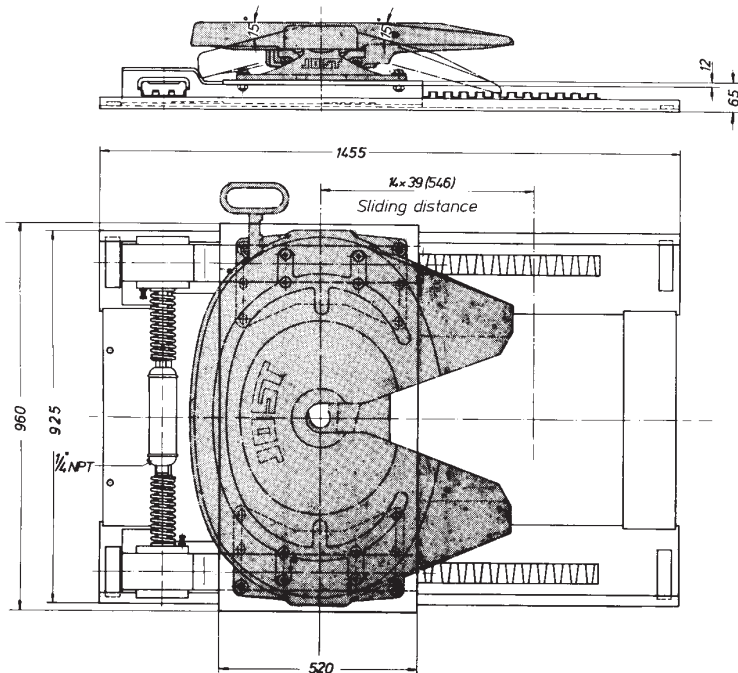
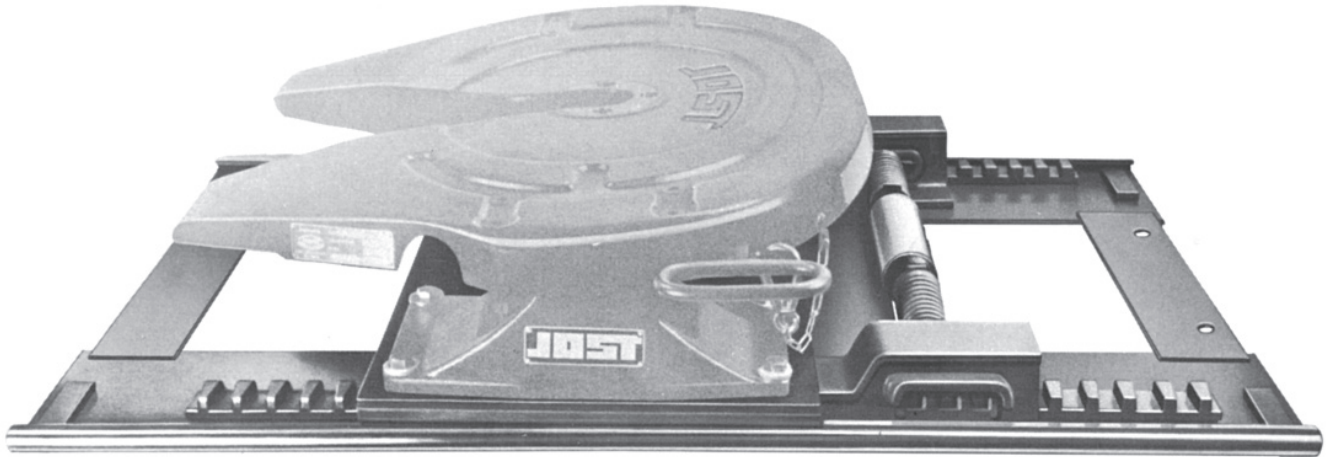

Load on main plate	18,000 kg
Total weight of articulated unit	135,000 kg
Weight approx. (without fifth wheel)	710 kg
D-value	190 kN
CRN	26168
For use with JSK 36 CV/150	
D-value	190 kN
CRN	26170
For use with JSK 37 CZ/150	
Base plate to suit European or standard spec	

The complete pneumatic actuating device (items 9 to 14 of spare parts list shown overleaf) is supplied.

The above loads apply to operation on ordinary roads and ordinary operating conditions as they are to be found in Europe. If the fifth wheels are being operated in other territories or under other conditions we would ask you to contact us regarding the type of fifth wheel to be used.

The right to alter specifications is reserved.

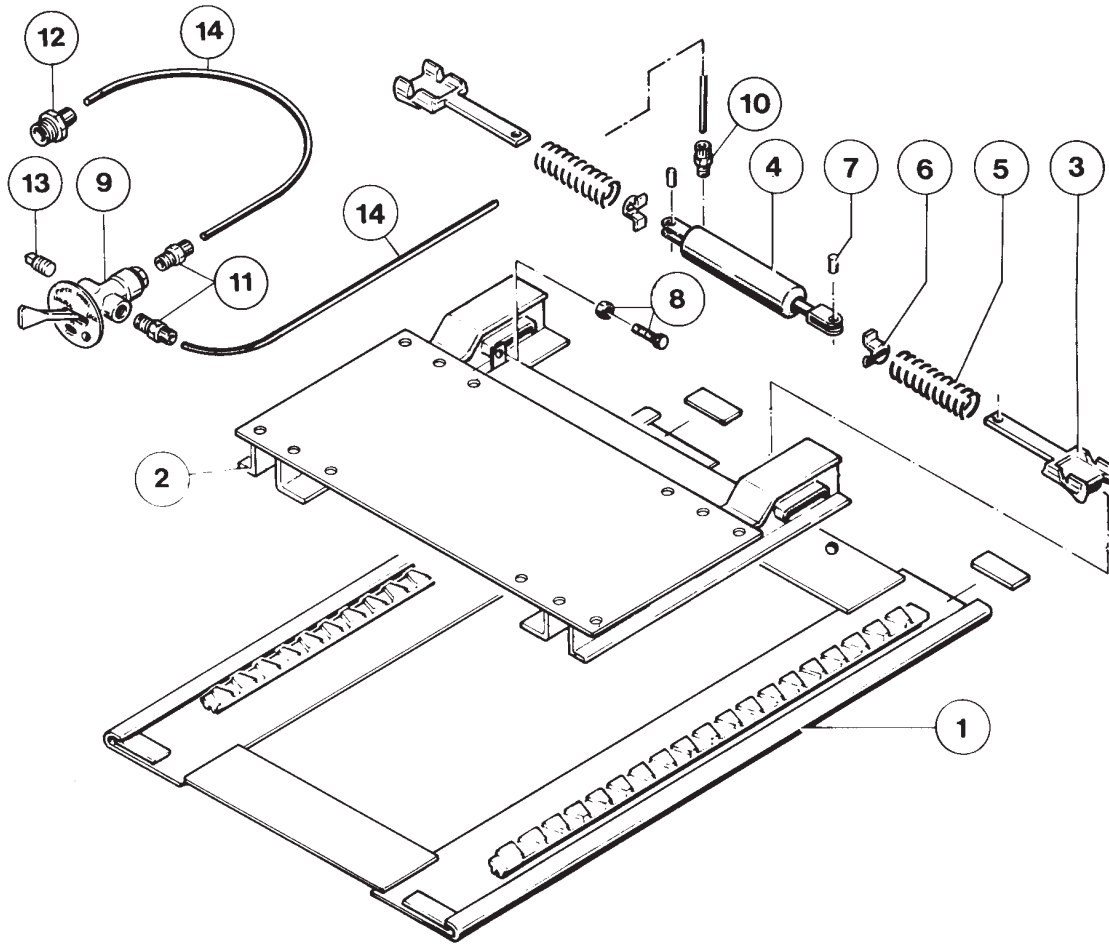

Fig.	Description	Part No.
1	Slider base plate 23"	V 1001-006
2	Slider upper part	V 1002-06
3	Locking plunger	V 1005-01
4	Air-cylinder	V 1021-05
5	Spring	V 1005-03
6	Spring retainer	V 1005-04
7	Pin	V 1005-05
8	Hexagon screw, compl.	V 1021-06
9	Air control valve, compl.	V 1021-18
10	Fitting	V 1021-13
11	Fitting	V 1021-14
12	Fitting	V 1021-15
13	Pipe plug	V 1021-17
14	Nylon airline	V 1021-16