

JSK 50

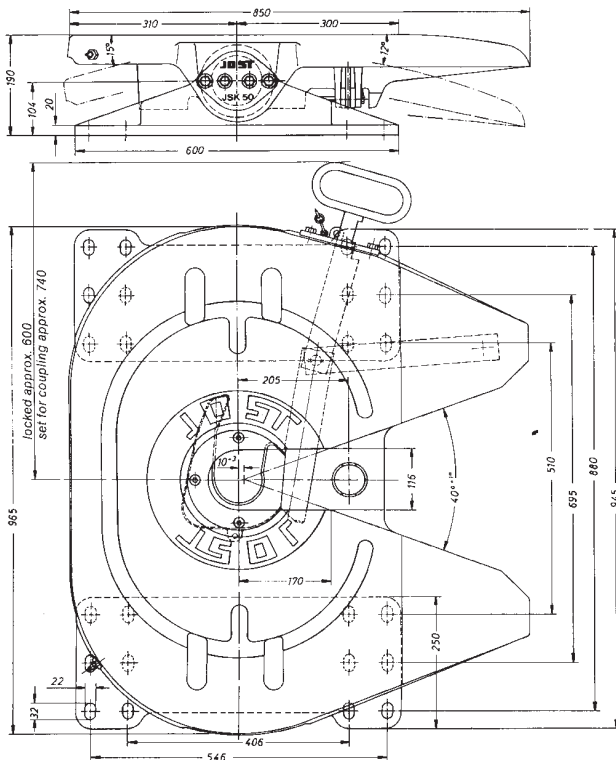
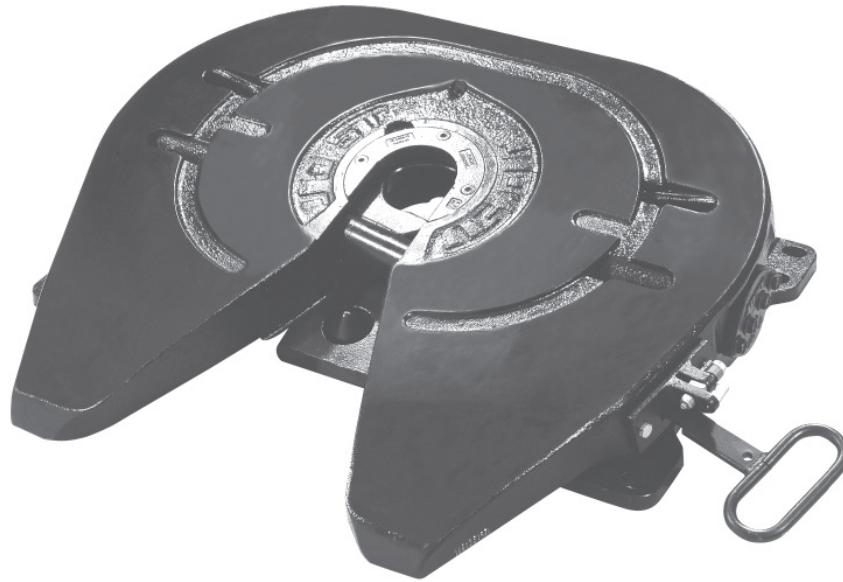

A heavy duty fifth wheel for arduous conditions

D rating 300 kN

imposed load up, to 50.000 kg.

JOST self-adjusting locking device for 3 1/2" King pins.

Suitable for all types of rear axle steering systems.

Weight: 290 Kg.

Bolt on type Pedestals

CRN

24502

Mounting must be carried out in accordance with our instructions.

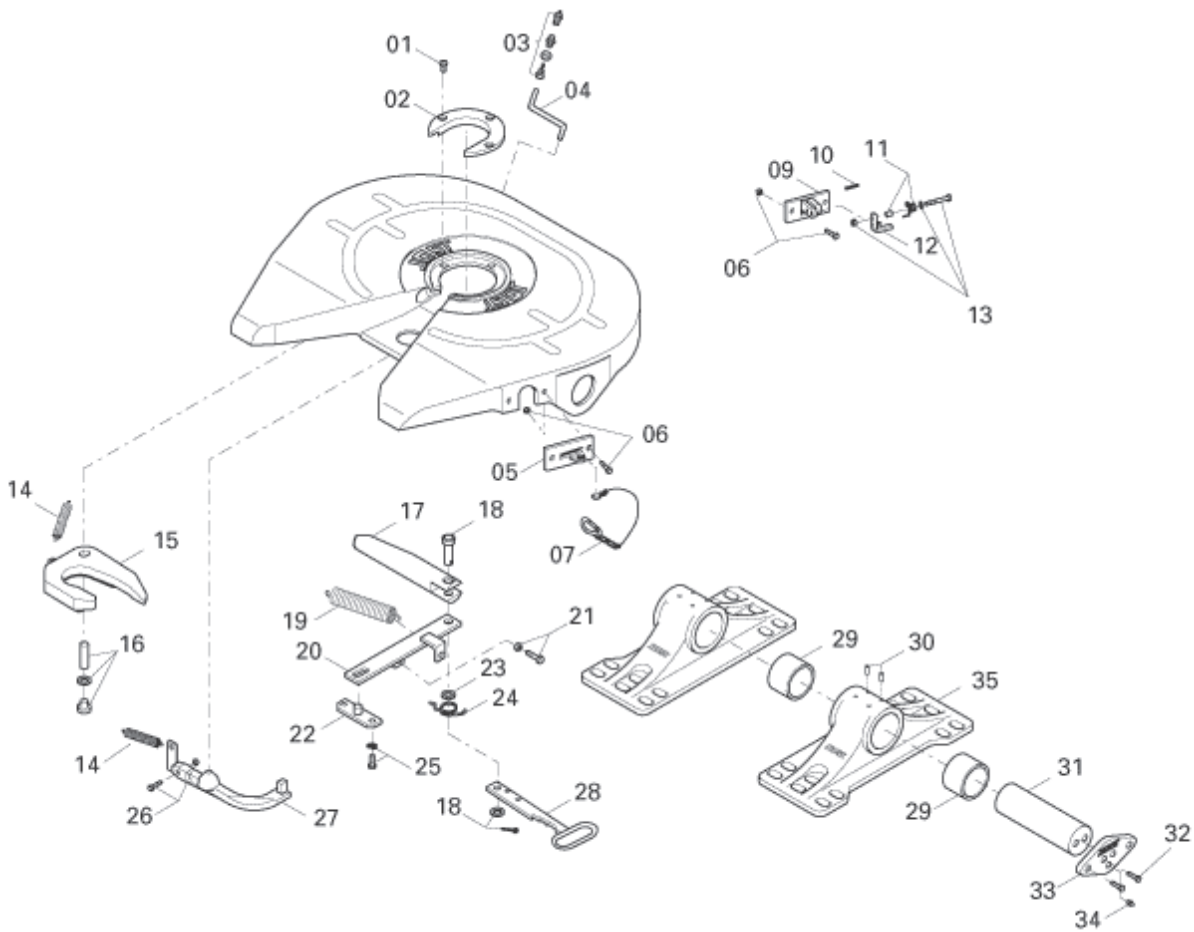

Fig.	Description	Part No.
1	Socket head bolt	SK 2421-08
2	Wearing ring 3 1/2", compl. with 1	SK 2421-56
3	Nut and bolt	SK 1976
4	Lubrication tube	SK 1989-003
5	Guide plate	SK 2405-22
6	Hexagon bolt, complete	SK 2421-50
7	Spring hook, complete	SK 1436
9	Latch holder, compl. with 10	SK 2405-084
10	Clamping pin	000.003.027
11	Spring noose with spacer	SK 2921-30
12	Latch, complete	SK 3121-52
13	Hexagon bolt, complete	SK 3521-03
14	Tension spring	SK 2106-01
15	Lock jaw 3 1/2"	SK 2405-14
15a	Lock jaw 3 1/2" to suit grease nipple	SK 2405-14Z
16	Bolt, complete	SK 2421-54
17	Locking bolt	SK 2405-01
18	Bar bolt, complete	SK 2121-14
19	Double tension spring	SK 2405-23
20	Lever	SK 2405-04
21	Hexagon bolt, complete	SK 2421-52
22	Bearing	SK 2405-15

Fig.	Description	Part No.
23	Washer	SK 2405-19
24	Spring noose	SK 2405-09
25	Hexagon bolt, complete	SK 2421-53
26	Hexagon bolt, complete	SK 2421-51
27	Latch	SK 2405-27
28	Handle	SK 2405-066
29	Bearing bushing	SK 2805-03
30	Cylindrical notched pin	SK 1533
31	Pivot pin	SK 2805-01
32	Locking bolt	SK 2521-05
33	Plate	SK 2805-02
34	Grease nipple	SK 2521-04
35	Pedestal, compl. with 29 + 30	SK 2821-51
Repair Kits		
1,2,5,7, 12,20, 27,28	Repair kit for lock 3 1/2"	SK 2421-76
Conversion Kits		
31,32, 34	Handle extension retrofit kit, complete	SK 2821-51

Note: Now Available with Automatic Secondary Locking

8/08