

JSK 38 DV90

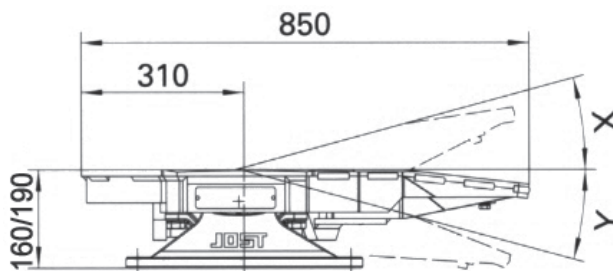
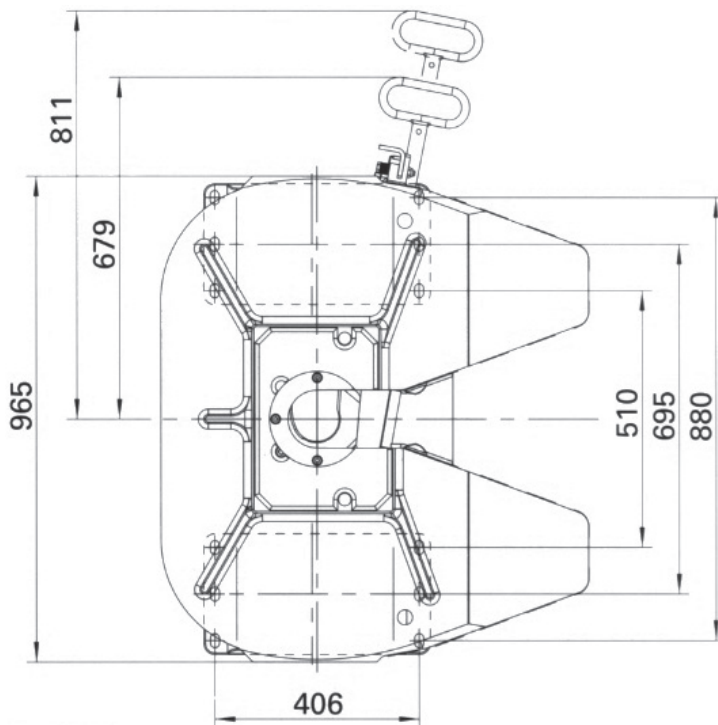
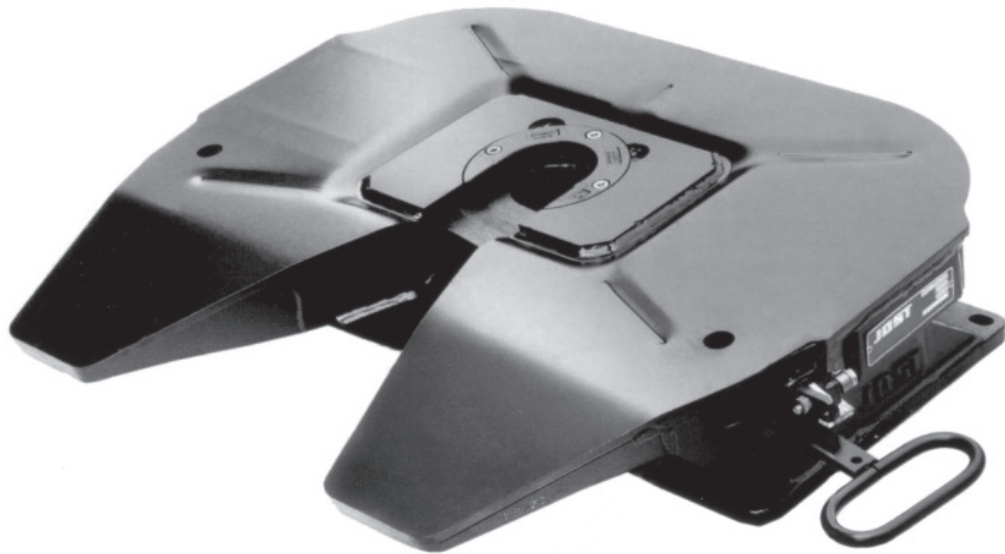

A heavy duty fifth wheel coupling for operation under arduous conditions.

Increased load (up to 28,000kg).

With rubber bearing (model "C"): rubber cushions are shock-absorbent and maintenance-free.

Technical specification:

Rubber bearing

The fifth wheel coupling complies with the directives/standards as per 94/20/EC - Class S, DIN 74084 and ISO 3842. Suitable for 3,5" (90) king pins as per 94/20/EC, DIN 74083 and ISO 4086. Fitted on a mounting plate.

Imposed weight	28,000kg
D-value	260kN
Weight	204kg
CRN	36688

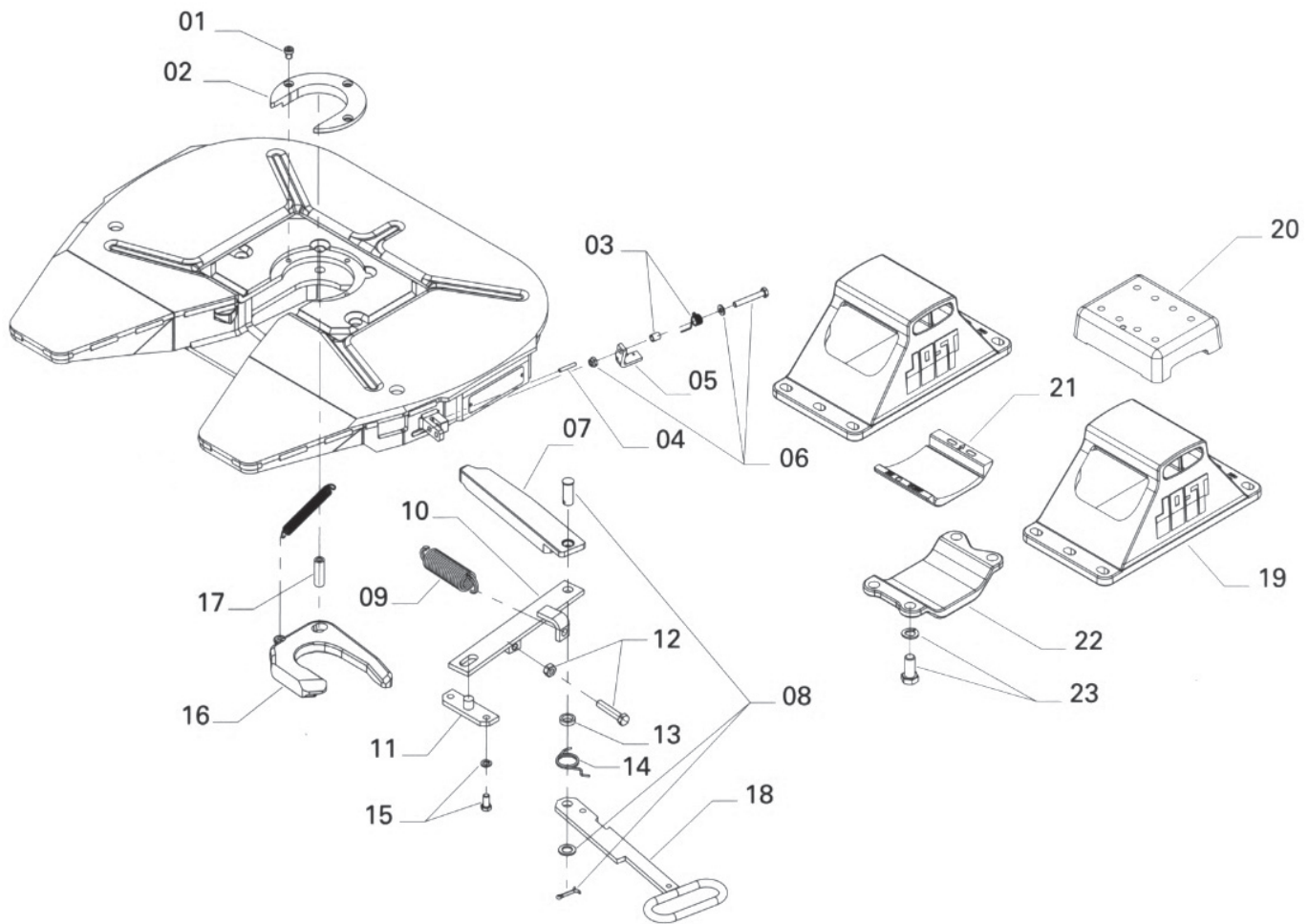

Fig.	Description	Part No.
1	Socket head bolt	SK 2421-08
2	Wearig ring, complete	SK 2421-56
3	Spring noose, complete	SK 2921-30
4	Clamping pin	000.003.027
5	Latch, complete	SK 3121-52
6	Hexagon bolt, complete	SK 3521-03
7	Locking bar	SKE003750000
8	Bar bolt, complete	SKE003760001
9	Double tension spring	SK 2405-23
10	Lever	SK 2405-24
11	Bearing	SK 2405-15
12	Hexagon bolt, complete	SK 2421-52
13	Washer	SK 2405-19

Fig.	Description	Part No.
14	Spring noose	SK 2405-09
15	Hexagon bolt, complete	SK 2405-53
16	Lock jaw	SK 2405-14
17	Bolt	SK 2405-18
18	Handle	SKE003740000
19a	Pedestal 160mm	SK 2404-05
19b	Pedestal 190mm	SK 2404-01
19c	Pedestal 250mm	SK 2404-04
20	Rubber cushion, upper	SK 2006
21	Rubber cushion, lower	SK 2007
22	Bridge	SK 2005
23	Hexagon bolt, complete	SK 2421-55