

DR 38 C-1, DR 38 C-2, DR 38 C-1/160, DR 38 C-2/160

with mounting pattern according to DIN standard 74081 and 74084

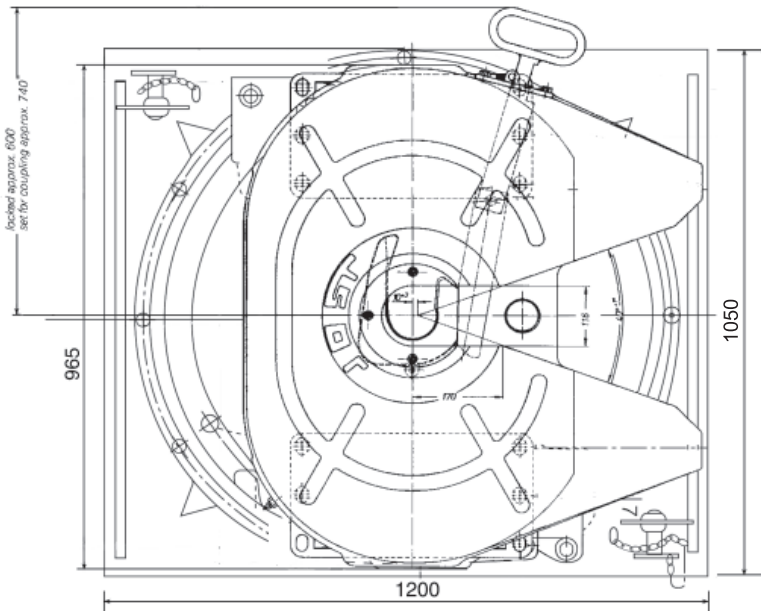
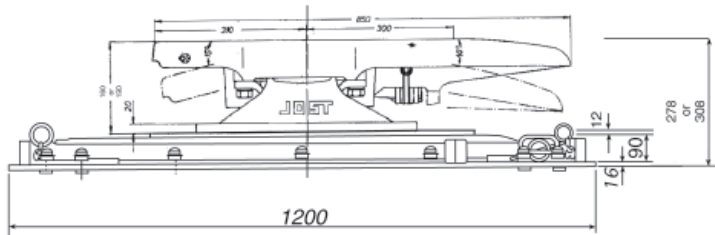
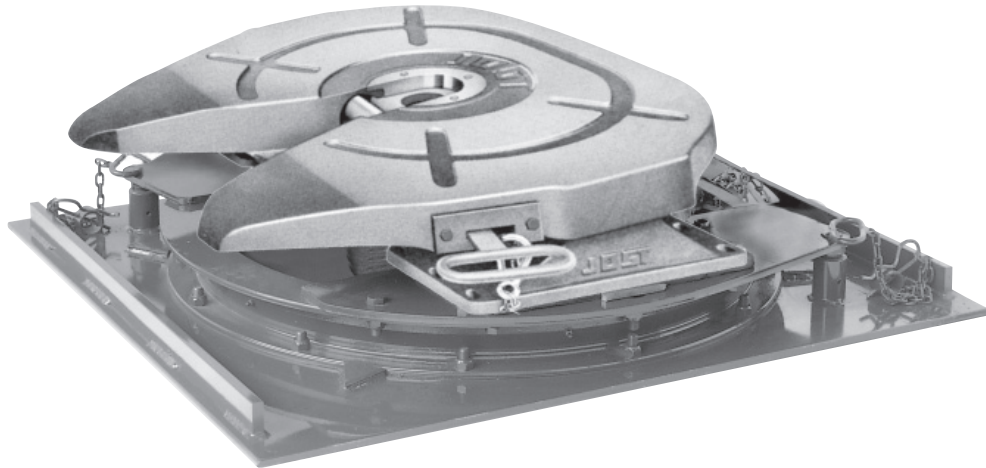

Heavy duty

Applications: Stock crate
Fridge van
General freight
Tankers

Standard with 16 mm base plate

optional: 20mm Base Plate

DR 38 C 20mm

*Note thicker base plate determines
extra weight and height.

D-Value JSK 38 C1W 260kN

JSK 38 C2W 216kN

Overall height 308 mm (with 190mm Feet)

278 mm (with 160mm Feet)

Imposed load 26000 kgs

Weight approx. 472 kgs

(for 16mm base plate)

CRN 38C1-24843

CRN 38C2-24841

Twin lockouts.

Flush bolt heads on mounting
plate in chassis mounting zone.

Cast type unit equipped with JSK
38 fifth wheel extra heavy duty
unit. Jaws sizes can be changed
from 50 mm or 90 mm diameter.

Mounting must be carried out in
accordance with our instructions.

Mounting must be carried out in accordance with our instructions.

The right to alter specifications is reserved.