



Scotseal TF Hubcaps

Heavy duty durability and dependability
from the wheel-end experts at SKF.



SKF Scotseal TF Hubcaps: Lighter than steel. Tougher than aluminum.

- Heavy duty durability
- Oil bath and grease-packed designs
- Compatible with all popular oils and greases including the latest synthetics
- Approved by all major OE truck and trailer manufacturers with growing number installing them as standard equipment
- Will run well over 450,000 maintenance-free miles
- Exclusion technology with multiple barriers protects seals and bearings from outside contamination.

Knowledge engineering by SKF

There are other hubcaps on the market, but none providing better wheel-end protection than Scotseal TF Hubcaps. Check out all the special features shown here, each designed to protect your wheel end components and extend the service life of bearings and hub units. For well over a decade, TF Hubcaps have helped fleets log literally billions of trouble-free miles. But what else would you expect from the company that has led the way in advanced bearing and seal technologies for 100 years.

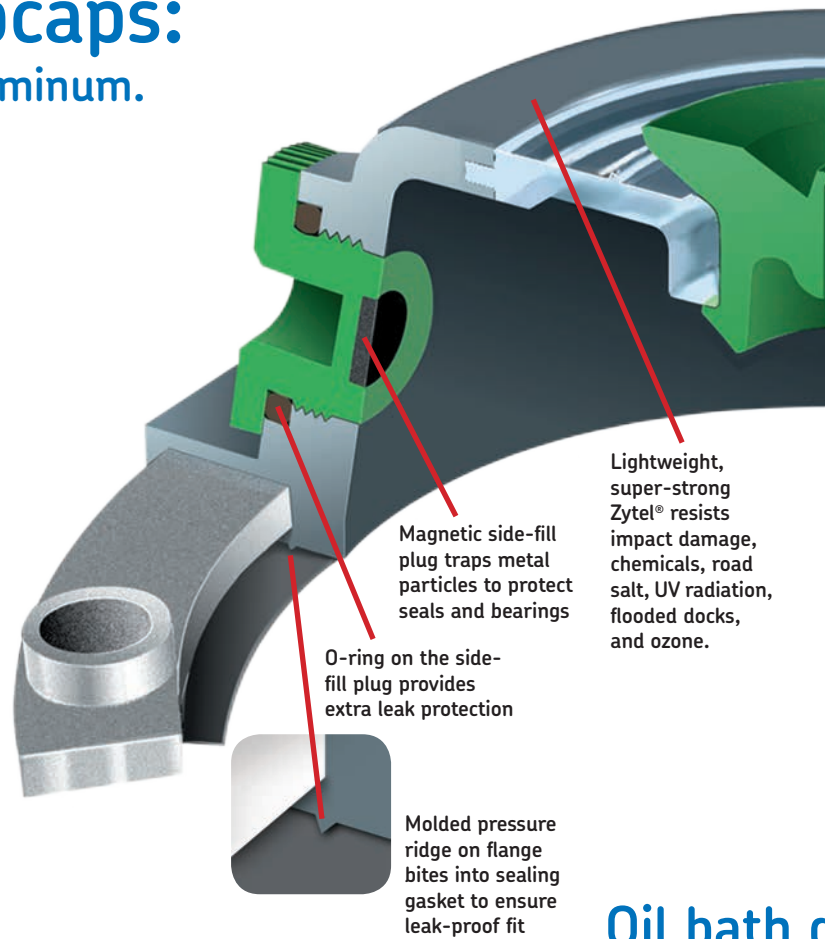

Oil bath o

SKF Splashguard Upgraded vent system and protection

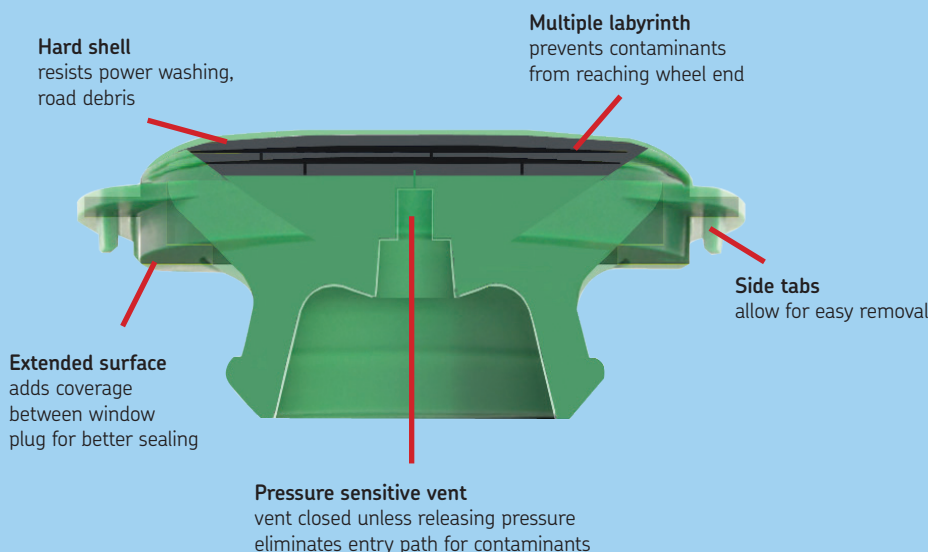

Splashguard center plugs are available in green and black 4 packs	Standard center plug	Splashguard center plug
Green	450434-4	450439-4
Black	453807-4	450438-4
Display (6 sets each)		454210
Display (12 sets green)		454215
Display (12 sets black)		454216

Contact us: info@wabco.cn

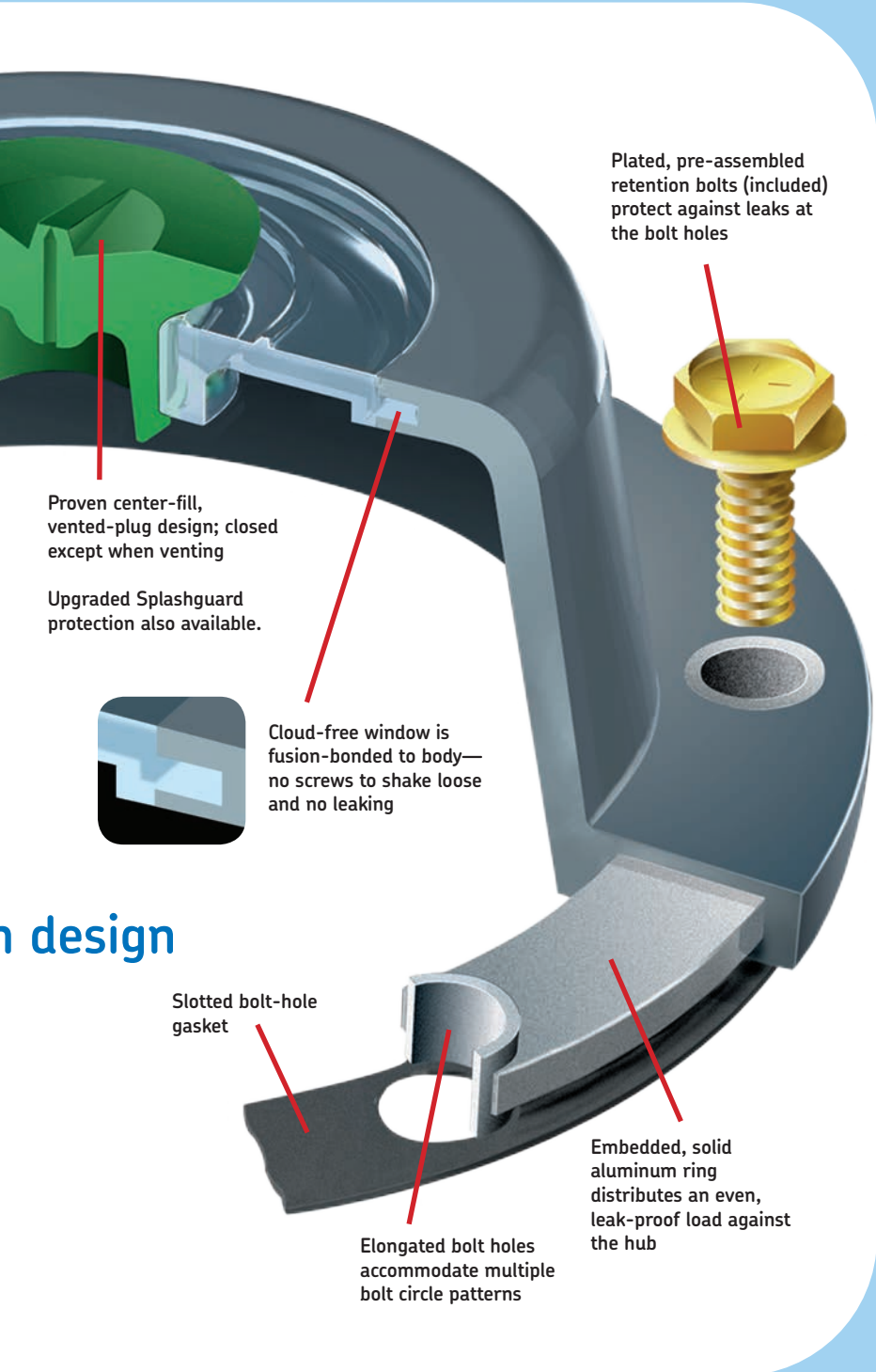

Plated, pre-assembled retention bolts (included) protect against leaks at the bolt holes

Proven center-fill, vented-plug design; closed except when venting

Upgraded Splashguard protection also available.



Cloud-free window is fusion-bonded to body—no screws to shake loose and no leaking

Slotted bolt-hole gasket

Embedded, solid aluminum ring distributes an even, leak-proof load against the hub

Elongated bolt holes accommodate multiple bolt circle patterns

n design

Other popular SKF hubcap designs



Scotseal® Stamped Steel

Zinc-plated and protected with weather-resistant armor to resist rust and rough wear. Available in 3- to 8-bolt designs.

New barrel part number for stamped steel hubcaps

1743B-100 - Barrel contains 100 bulk stamped hubcaps with gasket and center-fill plug plus SKF product decal.



Scotseal Lexan®

Lightweight, molded design handles harsh conditions; sealed models offered for grease-packed systems. Available for oil and grease pro-par applications.

SKF Scotseal TF hubcaps equipped for P.S.I.

The SKF hubcap line just got stronger. You can now equip your trailers with the SKF Scotseal TF hubcaps you prefer. SKF hubcaps equipped for P.S.I. incorporate the same durable and leak-proof technology you count on from the SKF Scotseal TF hubcaps. Four new SKF hubcaps are compatible with the Meritor® Tire Inflation System (MTIS) by P.S.I., an automatic tire inflation system (ATIS™). The system increases tire life, fuel efficiency and vehicle productivity.



Tamper-Proof Scotseal TF for grease-packed applications



Designed for today's grease-packed systems, the Tamper-Proof Scotseal TF Hubcap features a patented "umbrella" style valve that seals contamination out, yet vents internal pressure as low as

2 P.S.I. The addition of a splash plate to the hubcap design helps protect against the harsh conditions created by road spray, power washers and flooded docks.



"Umbrella" valve vents pressure even when covered with 1/4" grease; Splash plate provides extra protection against power washers

SKF Hubcap barrel program:

Order the most popular SKF hubcaps in barrel quantities.

Order by SKF barrel multi-pack part numbers:

- 1343B-100 – Trailer axle (grease)
- 1399B-75 – Trailer Pro-Par axle (grease)
- 1612B-100 – Steer axle (oil) – black
- 1643B-100 – Trailer axle (oil)
- 1644B-100 – Trailer axle (oil) – black
- 1696B-75 – Trailer Pro-Par axle (oil)

Order by number of hubcaps contained in barrel (i.e. 100 pcs of 1643B-100 or 75 pcs of 1696B-75)

Each barrel contains:

- 100 bulk packed hubcaps with gaskets and (6) 453963 fastening bolts
- Packaged individually in heavy duty plastic
- 16" x 16" SKF product decal

Order in case lots of 24

Save 10% to 20% vs individual boxed items!

Part number	Description
1343-C24	Gray TN Trailer Axle Hubcap-Grease
1612-C24	Black Steer Axle Hubcap-Oil
1643-C24	Gray TN Trailer Axle Hubcap-Oil
1644-C24	Black TN Trailer Axle Hubcap-Oil



1612 / 1643 / 1644 / 1696

- Lightweight DuPont Zytel material
- Embedded solid aluminum ring, distributes an even, leak proof load against the hub
- Increased impact resistant
- Leak-proof window is fusion-bonded to body



1343 / 1399

- Designed for semi-fluid grease applications
- Tamper-proof design
- "Umbrella" valve vent seals out contaminations yet vents internal pressure as low as 2 psi when covered by 1/4" of grease

Contact us: info@wabco.cn

Scotseal TF numerical list

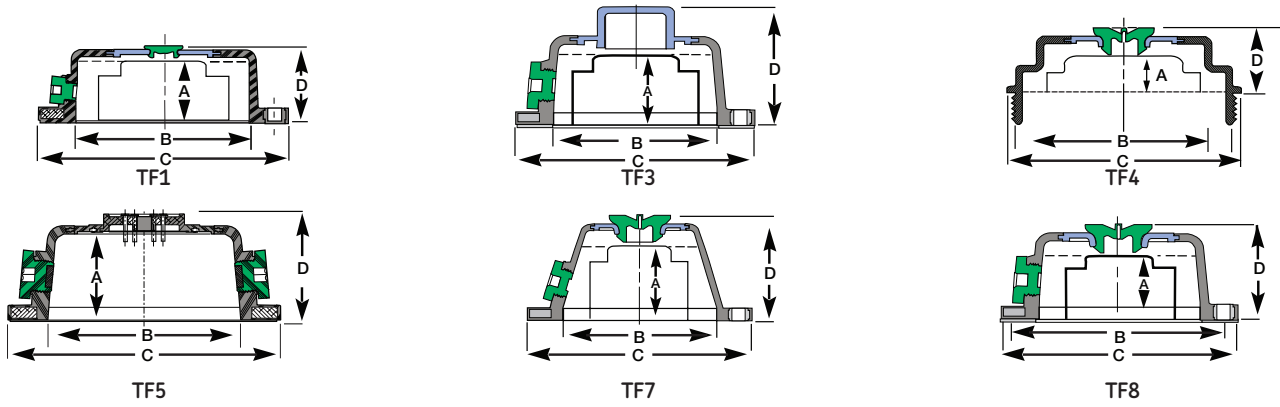

SKF number					Bolt holes	Hole size	Bolt circle	Max. axle Ext. (A)	Hubcap size			Type
Hubcap kit	Gasket**	Std. Plug**	Splashguard plug**	Side fill**					I.D. (B)	O.D. (C)	Height (D)	
1282**	454051-4	450434-4	450439-4	-	6.250 x 8 O.D.	Threaded	1.886	6.060	6.465	1.750	TF4	
1600♦	453795-8	-	-	453770-4 ¹	6	.349	5.500-5.562	1.990	4.432	6.250	3.082	TF3
1608*	453868-8	453879-4	-	453811-4	4	.349	3.625	1.808	2.400	4.313	2.024	TF8
1612*■	453869-8	453807-4	450438-4	453811-4	6	.349	4.500	1.880	3.500	5.250	2.609	TF8
1613*	453795-8	453879-4	-	453942-4	6	.349	5.500-5.562	1.586	4.385	6.250	1.643	TF1
1623	453909-8	450434-4	450439-4	453770-4 ¹	6	.349	5.125-5.250	2.125	4.132	6.000	2.632	TF8
1627	453912-8	450434-4	450439-4	453770-4 ¹	3	.416	5.250	2.125	4.132	6.000	2.632	TF8
1630*	453795-8	453807-4	450438-4	453811-4	6	.349	5.500-5.562	2.220	4.290	6.250	2.727	TF7
1642	453818-4	450434-4	450439-4	453770-4 ¹	5	.349	5.500	1.730	4.440	6.250	2.469	TF8
1643■	453795-8	450434-4	450439-4	453770-4 ¹	6	.349	5.500-5.562	1.730	4.440	6.250	2.469	TF8
1644*■	453795-8	453807-4	450438-4	453811-4	6	.349	5.500-5.562	1.730	4.440	6.250	2.469	TF8
1665	453909-8	450434-4	450439-4	453770-4 ¹	6	.349	5.125-5.250	1.400	4.132	6.000	1.905	TF8
1669*	453918-8	453813-4	-	453819-4	6	.349	5.875	1.323	4.715	6.580	1.600	TF8
1670*	453825-8	450434-4	450439-4	453770-4 ¹	6	.286	6.625	1.775	5.526	7.344	2.564	TF8
1681	453915-8	450434-4	450439-4	453770 ¹	4	.349	5.000	1.375	4.060	5.615	1.880	TF8
1691*	453795-8	453879-4	-	453942-4	6	.349	5.500-5.562	1.120	4.257	6.250	1.397	TF1
1696■	450799-8	450434-4	450439-4	453770 ¹	6	.349	6.750	2.887	5.625	7.500	3.688	TF8
1698	453906-8	450434-4	450439-4	453770 ¹	6	.416	6.000	2.000	5.000	6.750	2.507	TF8
1943*	453795-8	-	-	453770(2) ¹	6	.349	5.500-5.562	1.703	4.420	6.250	2.441	TF5
1996*	453795-8	-	-	453770(2) ¹	6	.349	6.750	2.805	5.627	7.500	3.650	TF5

* Black ** Lexan design ♦Hubodometer mount design *Designed for PSI system ■Available as Splashguard caps (i.e. 1612-SG) **Order in multi-pack part numbers
1) Component item only, not sold separately

Tamper proof

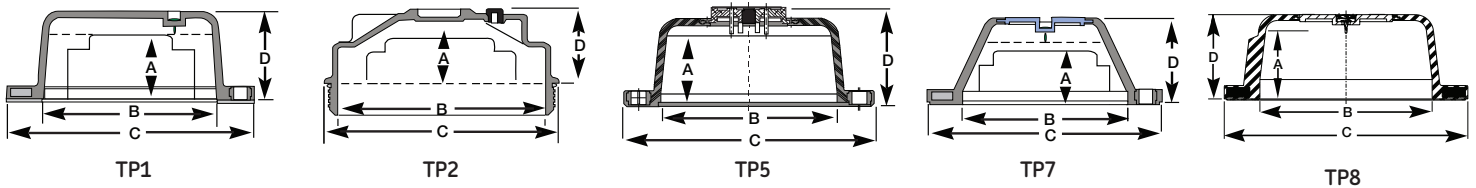

SKF number					Max. axle Ext. (A)	Hubcap size			Type
Hubcap kit	Replacement gasket**	Bolt holes	Hole size	Bolt circle		I.D. (B)	O.D. (C)	Height (D)	
1284**	454051-4	6	0.349	4.500	1.801	6.060	6.465	1.516	TP2
1326	450755-8	6	0.349	5.500	1.781	3.500	5.250	2.370	TP1
1327	453795-8	6	0.349	5.500	1.703	4.440	6.250	2.161	TP1
1343	453795-8	6	0.349	5.500-5.562	1.703	4.420	6.250	2.161	TP1
1343W	453795-8	6	0.349	5.500-5.562	1.703	4.420	6.250	2.161	TP8
1399	450799-8	6	0.349	6.750	2.805	5.662	7.500	3.455	TP1
1399W	450799-8	6	0.349	6.750	2.805	5.627	7.500	3.64	TP8
1443*	453795-8	6	0.349	5.500-5.562	1.703	4.420	6.250	2.443	TP5
1499*	450799-8	6	0.349	6.750	2.805	3.640	7.500	3.640	TP5

**Lexan design *Designed for PSI system **Order in multi-pack part numbers



SKF Hubcap interchange reference chart

SKF TF/Zytel			Stemco				National Oil	Dual Dynamics				
Oil	Grease	Application	Oil			Sentinel		Oil	Grease	SKF Steel		
						Oil	Grease					
1282 ²	1284 ²	Pro-Par Trailer		343-4975			348-4075	349-4075	HU-075A	276-P	275-G	
1600		Trailer/Hubo	347-4009									
1608 ¹		Steer	340-4065	343-4065					HU-065A			
1612 ¹	1326 ¹	Steer	340-4024	343-4024	350-4024				HU-024A	302-P	301-G	1711
1613 ¹		Steer	340-4249	343-4249	350-4249				HU-149A			1703
1623		Trailer	340-4066	343-4066					HU-066A			1723
1627		Trailer	340-4002	343-4002								1727
1627		Steer	340-4019	343-4019					HU-019A			
1630 ¹		Trailer	340-4014	343-4014							202-G	
1642		Trailer	340-4013	343-4013			348-4013	349-4013	HU-013A	282-P		1742
1643	1343	Trailer	340-4009	343-4009			348-4009	349-4009	HU-009A	203-P	283-G	1743
1643	1343	Trailer	340-4046	343-4046					HU-046A	303-P	304-G	
1644 ¹	1343	Trailer/Steer	340-4009	343-4009			348-4009	349-4009				1743
	1343W	Trailer						342-4009				
1665		Trailer	340-4042	343-4042					HU-042A			1765
1669 ¹		Steer	340-4025	343-4025	350-4025				HU-036A			
1670 ¹		Steer	340-4034	343-4034	350-4034				HU-034A			1770
1681		Trailer	340-4029	343-4029					HU-028A			
1691 ¹		Steer	340-4098	343-4098								1790
1696	1399	Trailer	340-4195	343-4195			348-4195	349-4195		257-P	255-G	1796
	1399W	Trailer						342-4195				
1698		Trailer	340-4059	343-4059								1798
1698		Trailer	340-4080	343-4080								
1943 ³	1443 ³	Trailer		343-4370				340-4350		207-P	401-G	
1996 ³	1499 ³	Trailer		343-4372				340-4352		260-P	456-G	

¹ Black design ² Lexan design ³ Designed for P.S.I. system

Contact us: info@wabco.cn